

ferroli

RLA

SPECIAL VERSIONS
AIR COOLED WATER HEAT PUMP AND
COOLERS WITH HELICAL FANS

**NEW
SERIES**

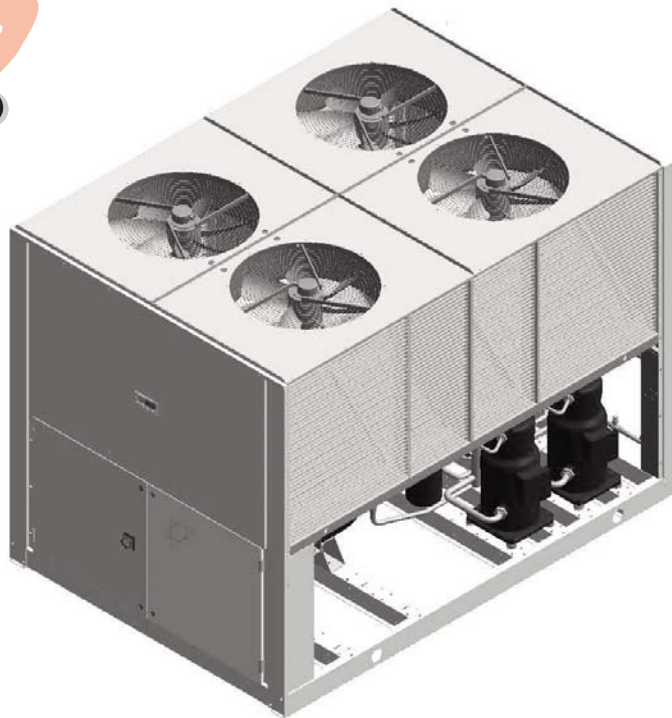

150.4
165.4
180.4
205.4
230.4
260.4
285.4
315.4

VD - VERSION WITH DESUPERHEATER
VP - VERSION WITH PARTIAL HEAT RECOVERY
VR - VERSION WITH TOTAL HEAT RECOVERY
VI - BRINE VERSION

TECHNICAL MANUAL

TABLE OF CONTENTS

THIS MANUAL IS DIVIDED INTO SECTIONS AND THE NAME OF EACH SECTION IS SHOWN AT THE TOP OF EACH PAGE

GENERAL SPECIFICATIONS	4
PRESENTATION OF THE UNIT	4
IDENTIFICATION CODE OF THE UNIT	4
DESCRIPTION OF THE COMPONENTS	5
SPECIAL VERSIONS	5
VERSION WITH DESUPERHEATER (VD) (available for both IR units and IP units)	6
TOTAL AND PARTIAL HEAT RECOVERY VERSION (VR-VP) (only available for IR units)	7
ACCESSORIES	7
TECH. SPEC. & STD PERF. - SPECIAL VERSIONS - IR UNITS FOR COOLING ONLY	8
GENERAL TECHNICAL SPECIFICATIONS	8
BASIC VERSION	8
VERSION WITH DESUPERHEATER (VD)	8
VERSION WITH PARTIAL RECOVERY (VP)	9
TOTAL RECOVERY VERSION (VR)	9
BRINE VERSION (VI)	9
NOISE LEVELS OF SPECIAL VERSIONS	9
STANDARD PERFORMANCES OF VERSION WITH DESUPERHEATER (VD)	10
STANDARD PERFORMANCES OF VERSION WITH PARTIAL RECOVERY (VP)	11
STANDARD PERFORMANCES WITH TOTAL RECOVERY VERSION (VR)	12
TECHNICAL SPECIFICATIONS AND STANDARD PERFORMANCES - SPECIAL VERSIONS - IP HEAT PUMP UNITS	13
GENERAL TECHNICAL SPECIFICATIONS	13
BASIC VERSION	13
VERSION WITH DESUPERHEATER (VD)	13
NOISE LEVELS OF SPECIAL VERSIONS	13
STANDARD PERFORMANCES OF VERSION WITH DESUPERHEATER (VD)	14
OPERATING RANGE	15
OPERATING LIMITS	15
HOW TO SELECT THE UNIT	16
EXAMPLE N°1 - SELECTION OF SPECIAL VERSION OF IR UNIT - COOLING MODE ONLY	16
EXAMPLE N°2 - SELECTION OF SPECIAL VERSION OF IP HEAT PUMP UNIT	19
WATER PRESSURE DROP WITH DESUPERHEATER	21
WATER PRESSURE DROP WITH PARTIAL RECOVERY	22
WATER PRESSURE DROP WITH TOTAL RECOVERY	23
OVERALL DIMENSIONS AND MINIMUM SPACE REQUIRED FOR OPERATION	24
OVERALL DIMENSIONS	24
DESCRIPTION OF THE COMPONENTS	24
MINIMUM SPACE REQUIRED FOR OPERATION	24
POSITION OF WET CONNECTIONS	25

THIS DOCUMENT DOES NOT SUBSTITUTE, BUT INTEGRATES AND COMPLETES THE TECHNICAL BULLETINS OF THE BASIC VERSION (VB) WITH SPECIFIC INFORMATION AND DATA CONCERNING THE SPECIAL VERSIONS (VD - VR - VP - VI) AVAILABLE.

GENERAL SPECIFICATIONS

Presentation of the unit

The Special Versions of this series of water chillers and heat pumps meet the particular and specific requirements of planning engineers and installers who wish to build systems able to operate in the most efficient way and achieve the utmost in energy savings.

The available Versions for IR units that operate in the Cooling Mode only, are:

-Heat recovery versions (VD - VR - VP)

-Version that produces water at a low temperature (VI).

The Version available for the IP Heat Pump unit is:

-Heat recovery versions with Desuperheater (VD)

The heat recovery versions (VD - VR - VP) recover part or all of the heat generated by the unit as it operates in the normal way. This means that the unit is used more efficiently and allows the heat normally generated to be recovered instead of being dissipated in the air and thus lost.

Deep research involving the units and their development beyond the Basic Version has allowed the typical noise levels and overall dimensions to be maintained unchanged: the addition of specific and appropriate heat exchangers within the cooling circuit integrates the main Basic structure, leaving the wet connections of the cold water circuit in the same position. This means that the same components as the Basic units (VB) can be used for the special versions and in particular, that the same main accessories can be used.

Besides the electrical and wet connections required for the basic version, installation of these units in the recovery version is simply completed by making the wet connections to the recovery circuit.

The (VI) Version produces water (usually containing brine) at temperatures below 4°C, down to -6°C. In view of the particular application, special attention was paid to sizing the components and pipes of the cooling circuit when the units were developed.

Moreover, to reduce heat dispersion and the formation of condensation to the utmost, the reservoir and all the cold pipes of the cooling and hydraulic circuits are insulated with very thick heat insulating material.



Identification code of the unit

The codes that identify the units are listed below and include the sequences of letters that determine the meanings for the various versions and set-ups.

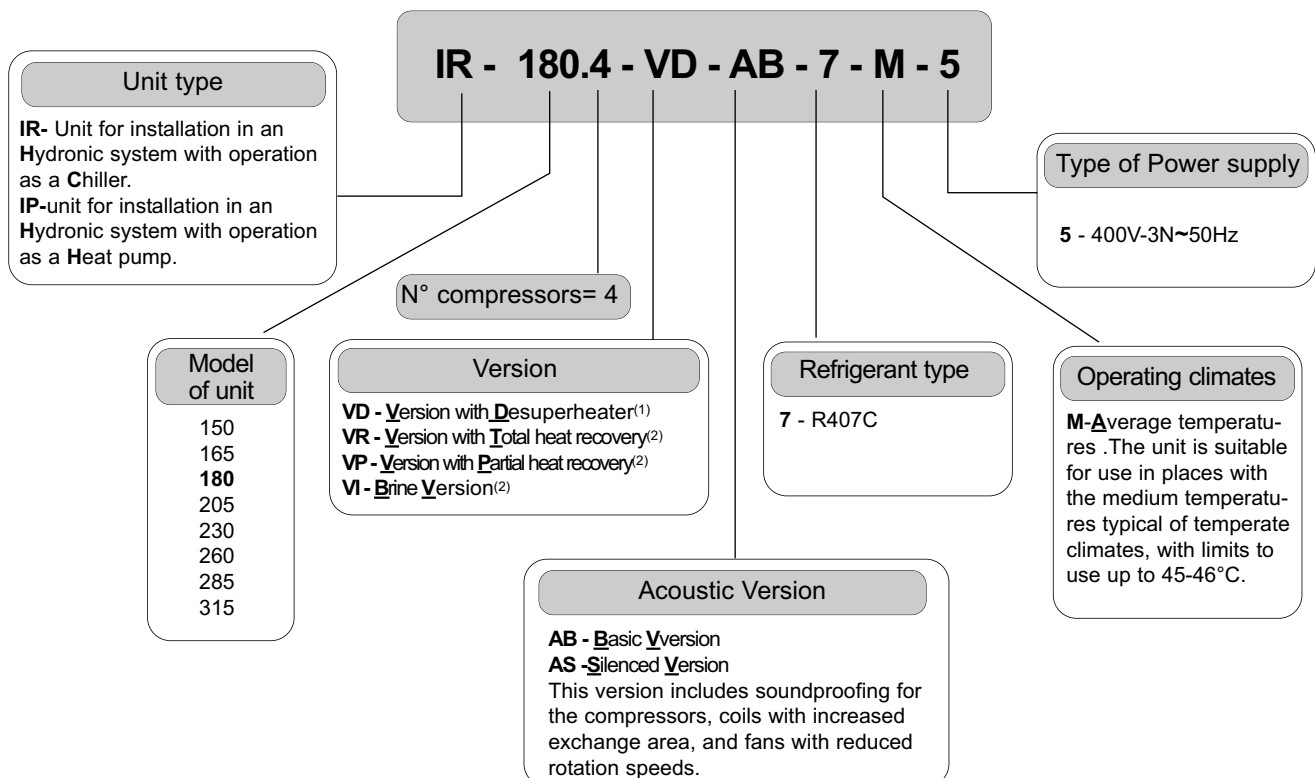

(1): Special Version available for both Cooling Mode only units (IR) and for Heat Pump units (IP)

(2): Special version available for Cooling Mode only units (IR)

GENERAL SPECIFICATIONS

Description of the components

- 1. Fans.** These are the helical type with scythe-shaped vanes to increase efficiency and reduce the sound emissions. The fans are directly coupled to the three-phase motor by means of an external rotor. Thermal protection against operating faults is installed inside the winding.
- 2. Bearing structure** made of galvanized sheet metal coated with polyurethane powder paint to ensure good protection against adverse weather conditions.
- 3. User interfacing terminal with display.**
 - On-off key.
 - Operating mode selector key.
 - Compressor on-off **LED**.
 - Antifreeze heaters on **LED**.
 - Check-control with alarm code display.
 - Defrosting in progress indicator.
- 4. Covering panels,** in galvanized sheet metal coated with polyurethane powder paints to ensure the utmost ability to withstand adverse weather conditions.
- 5. Electric control and monitoring panel.** It is housed in a cabinet made of adequately thick painted sheet metal suitable for outdoor installation (protection degree IP 54). The panel comprises the following main components:
 - Main door-locking circuit-breaker.
 - Disconnectable fuse holders with protection fuses for each compressor.
 - Disconnectable fuse holders with protection fuses for the oil heaters of the compressors.
 - Fan speed control board.
 - Control contactor for each compressor.
 - Disconnectable fuse holders and fan protection fuses.
 - Fan control contactors.
 - Magnetothermic relay/s and contactor/s for the pump/s (if one of the pumping module accessories is installed and depending on the type chosen).
 - Disconnectable fuse holders with protection fuses for the antifreeze heater.
 - Insulating and safety transformer to power the auxiliaries, protected with fuses.
 - Basic monitoring board with microprocessor:

The main functions of the monitoring system are:
 Temperature regulation of the water produced by the unit, defrosting control (only **IP** units), operating hour counting and management for compressors and pump/s, balancing of operating hours for compressors, start-up timing, parameter entry digitized via the keyboard, alarm diagnosis, management and regulation of the temperature of the water produced by the heat recuperator (only for **VR** and **VP** models).

Functions associated with the digital inputs: low and high pressure, differential pressure switch / evaporator water flow switch and differential pressure switch / heat recovery water flow switch (only for **VR** and **VP** models), high discharge temperature, correct electric power enabling phase presence-sequence, thermal protection for compressors, thermal protection for fans, thermal protection for pump/s, remote controlled ON/OFF commands, recovery enabling (only for **VR** and **VP** models), ON/OFF and operating mode change (only for **IP** models).

Functions associated with the digital outputs: compressor control, water pump/s control, electric antifreeze heater, fan control, general alarm (can be remote controlled), recovery valve/s control (only for **VR** and **VP** model), cycle reversing valve control (only for **IP** models).

Functions associated with the analog inputs: evaporator water inlet and outlet temperature, coil temperature, heat recuperator water inlet and outlet temperature (only for **VR** and **VP** models).
- 6. Compressors.** These are the **SCROLL** type with orbiting coil equipped with built-in thermal protection and oil heater. As part of the standard supply, they are positioned on rubber vibration dampers to reduce the vibrations transmitted to the base of the unit. To lower the sound emission of silenced version **AS**, they are installed in a soundproofed booth made of galvanized sheet metal coated with polyurethane powder paints and covered in soundproofing material.
- 7. Condensing/evaporating bank,** the aluminium finned pack type with shaped profile to increase the heat exchange coefficient and with copper pipes arranged in staggered rows, together with a subcooling circuit. A sub-cooling section is built into the lower part for **IR** units only.

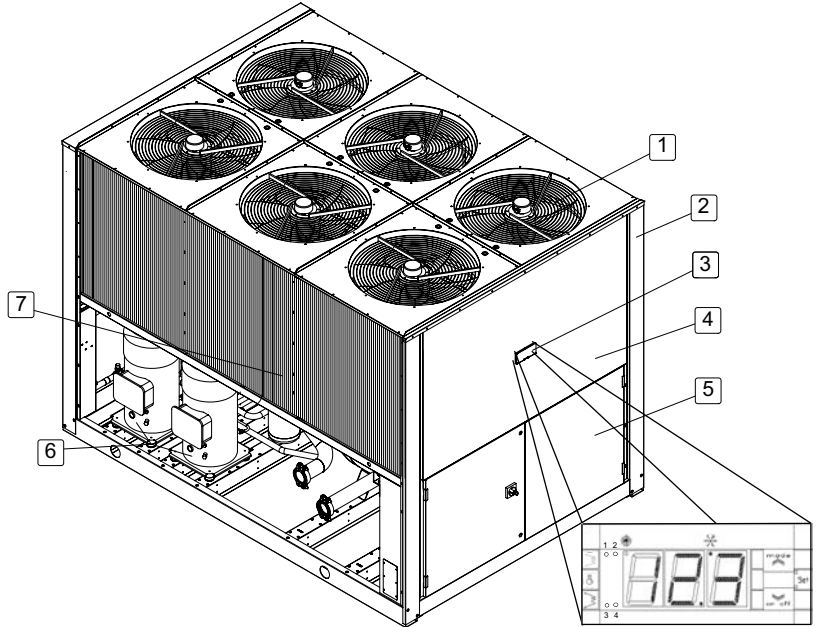

Special Versions

The available special versions are described below:

- VD: Version with Desuperheater (available for both IR units and IP units)**
 Produces cold water in the same way as the basic version plus hot water from **40 to 70°C** at the same time. This is achieved by installing a water-refrigerant gas heat exchanger between the compressor and coils in order to recover 15 to 20% of the heating capacity that would otherwise be dispersed in the air.
- VR: Total Heat Recovery version (only available for IR units)**
 Produces cold water as in the basic version plus hot water at a temperature of **35 to 50°C** at the same time. This is achieved thanks to a water-refrigerant gas heat exchanger that totally recovers the heating capacity that would otherwise be dispersed in the air. The total heat recovery function is enabled and disabled by means of a valve on the compressor delivery of each circuit: when the temperature of the water that enters the recuperator drops, the valve switches the hot gas flow from the condensing coils to the recovery heat exchanger. On the other hand, when the temperature of the water reaches the set-point, the valve shuts off the heat recuperator and switches the hot gas flow to the condensing coils.
- VP: Version with partial heat Recovery (only available for IR units)**
 The heat recovery operation takes place in the same way as the **VR total heat recovery** version, but just involves one cooling circuit instead of both.
- VI: Version that produces water at a low temperature (BRINE) (available for IR units only)**
 The unit can produce cold water with brine at a temperature of **-6 to 4°C**.

GENERAL SPECIFICATIONS

Version with Desuperheater (VD) (available for both IR units and IP units)

Hydraulic and chilling circuit components:

- 1. Manual water drain pipe.** To use in conjunction with the water drain cocks for emptying the exchangers and pipes dedicated to heat recovery.
- 2. Air vent.** The automatic type, positioned on the highest part of the pipes.
- 3. Water safety valve.** On the heat recovery inlet pipe. It acts whenever faulty service leads to an operating pressure in the plumbing system that exceeds the valve opening value.
- 4. Desuperheater.** Specially designed for the specific version. Plate type, made of stainless steel (AISI 316). It is installed within a shell of thermal barrier insulating material to prevent heat exchanges towards the outside. Standard supply also includes an electric antifreeze heater to prevent the parts from freezing during the winter, when the system remains at a standstill (if not drained).
- 5. Water drain cock** (one for each desuperheater) for emptying the exchangers and pipes of the machine dedicated to heat recovery.

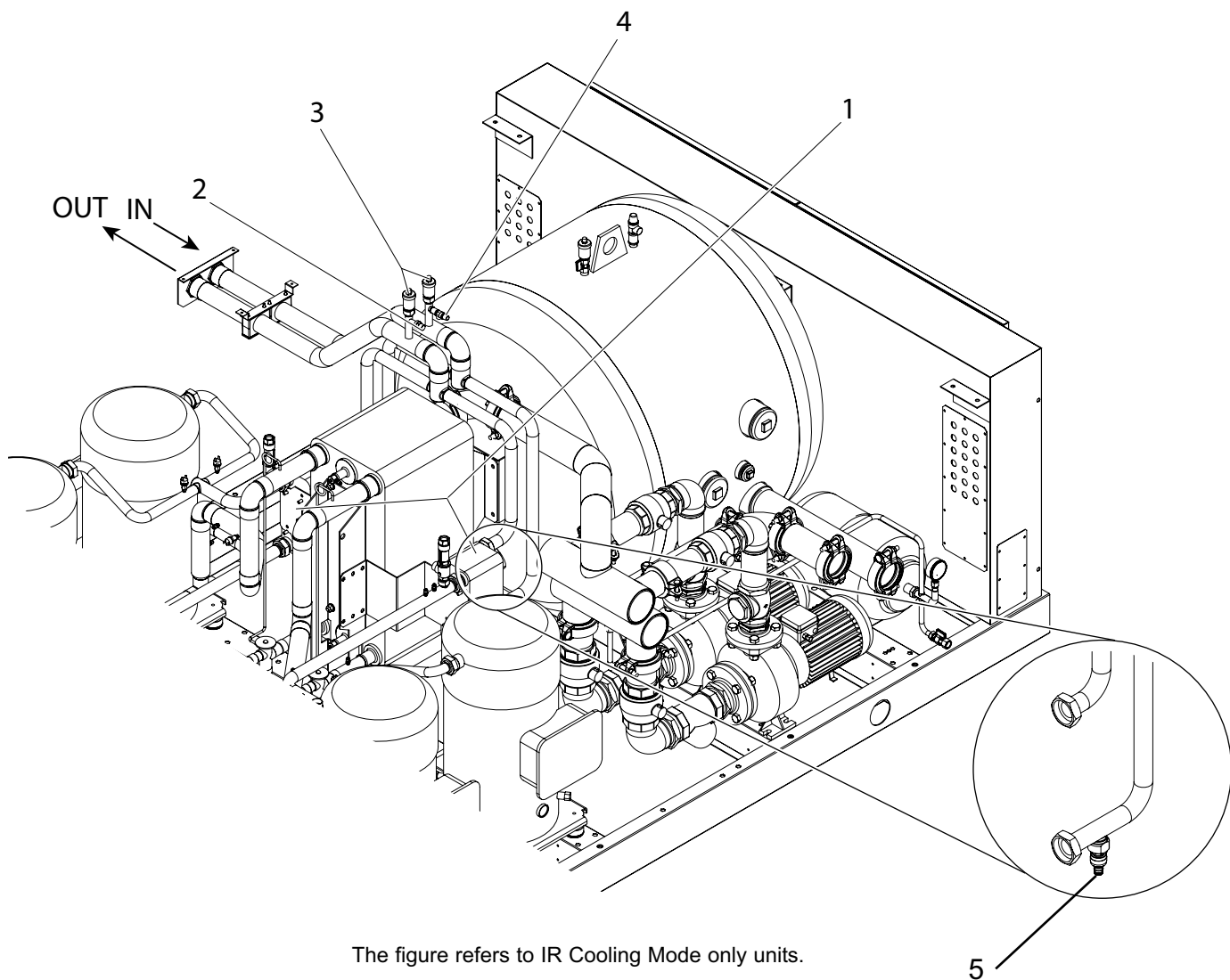

The figure refers to IR Cooling Mode only units.

GENERAL SPECIFICATIONS

Total and Partial Heat Recovery (VR-VP) (only available for IR units)

Hydraulic and cooling circuit components:

1A-1B. Heat recovery exchanger. Specially designed for the specific version. Plate type, made of stainless steel (AISI 316). It is installed within a shell of thermal barrier insulating material to prevent heat dispersion towards the outside. Standard supply also includes an electric antifreeze heater to prevent the parts from freezing during the winter, if it is not drained.

Differential water pressure switch. Installed on exchanger 1A. It disables the heat recovery version if activated owing to lack of water flowing through the recovery exchangers.

Heat recovery management valve. This delivers refrigerant to the condensing coils or heat recovery exchanger, depending on demands for hot water, and into the appropriate exchangers depending on whether hot water is required or not.

Fluid receiver. This is a plenum tank that accounts for the refrigerant charge variations required by the machine as the operating modes change (condensing in air or in water).

Fluid solenoid valves. Allow the refrigerant charge to be recovered after operating mode changes from recovery to cooling and vice versa.

One-way valves. Make the refrigerant obligatorily pass through the appropriate heat exchangers (coils / heat exchanger), depending on the operating mode.

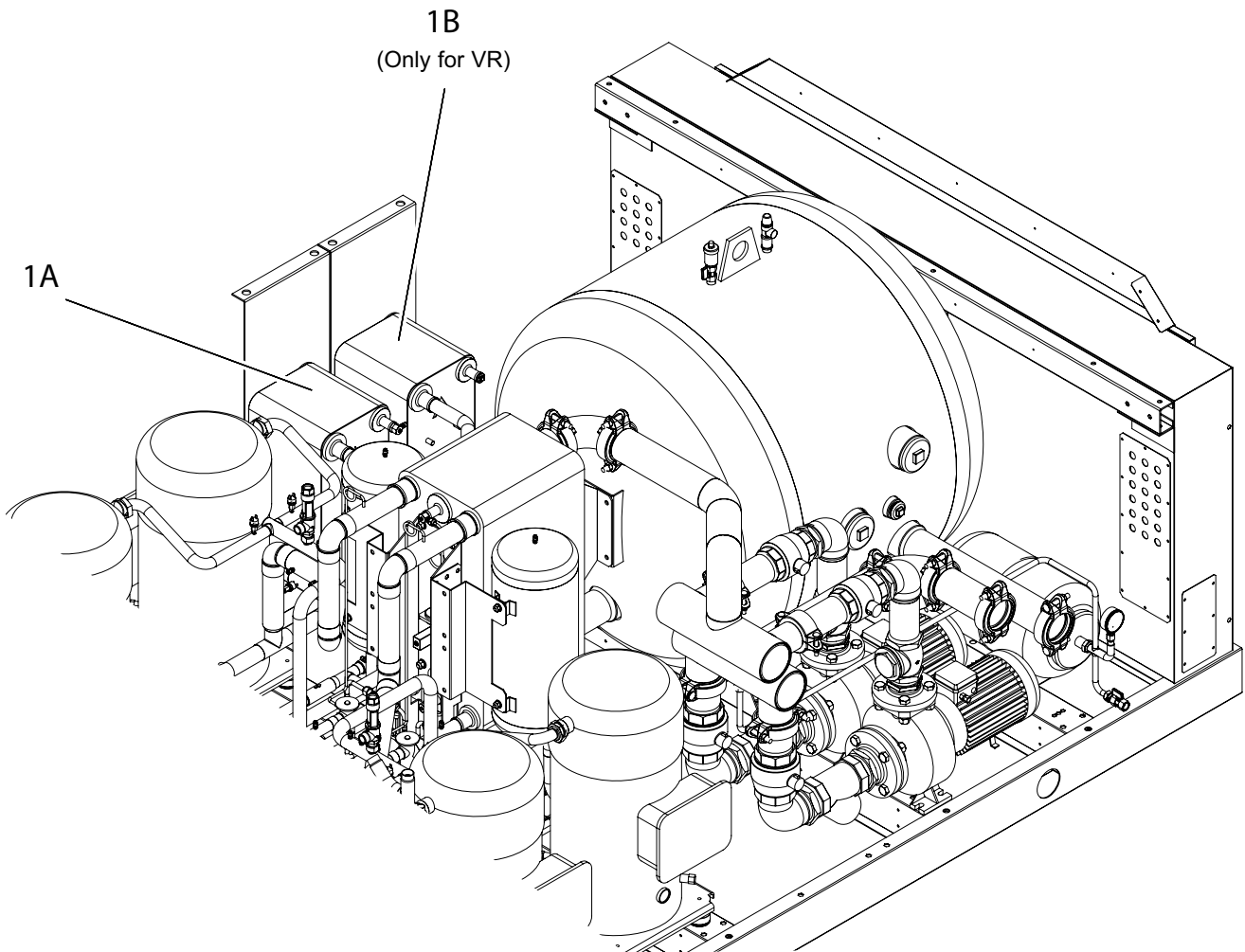

Accessories

Refer to the Technical Bulletin of the Basic Version of the Cooling mode only unit and Heat Pump for the available accessories.

TECH. SPEC. & STD PERF. - SPECIAL VERSIONS - IR UNITS FOR COOLING ONLY

General technical specifications

The following data refer to IR units using R407C refrigerant

Model	150	165	180	205	230	260	285	315	MU
Shipping volume of unit	17.6						18.2		m ³

Compressor specifications

Type	SCROLL								/
Quantity	4								N°

Exchanger data

Type	WITH PLATES								/
Quantity	1								N°
Water capacity	11.4	13.3	14.3	23.9	27.5	30.2	32.9	37.4	l

Water tank specifications ⁽¹⁾

Water capacity	700								l
----------------	-----	--	--	--	--	--	--	--	---

(1): The water storage tank is an accessory that must be requested when the unit is ordered.

Specifications of coils with extended surfaces

Type	COPPER PIPES NOTCHED ALUMINIUM FINNS								/	
Quantity	4								N°	
Total area	11.6								m ²	
N° Fans diameter 800 mm	4		4	6*	4	6*	6	6	6	N°

(*): Fans installed in Silenced Version only.

Basic version

Technical specifications of Basic unit AB-7M5

Model	150	165	180	205	230	260	285	315	UM
Net cooling capacity ⁽²⁾	149	163	177	204	228	253	282	311	kW
Net total power input ⁽²⁾	62.9	67.9	73.1	82.4	91.5	104	118	129	kW
Gross cooling capacity ^{(2)(E)}	-	-	178	205	229	255	284	313	kW
Gross total power input ^{(2)(E)}	-	-	72.1	81.0	90.2	102	115	126	kW

Technical specifications of Silenced unit AS-7M5

Net cooling capacity ⁽²⁾	146	160	173	200	224	248	275	302	kW
Net total power input ⁽²⁾	62.0	67.0	72.3	84.6	93.7	102	114	125	kW
Gross cooling capacity ^{(2)(E)}	-	-	174	201	225	250	277	304	kW
Gross total power input ^{(2)(E)}	-	-	71.3	83.4	92.2	100	112	123	kW

(2): The data refer to: Water temperature: inlet: 12°C - outlet: 7°C.
Outdoor air temperature 35°C D.B.

(E):Data certificated by EUROVENT.

Version with Desuperheater (VD)

Recovery heat exchanger specifications

Model	150	165	180	205	230	260	285	315	MU
Type of recovery exchanger	BRAZE WELDED STAINLESS STEEL PLATES								/
Quantity	2								N°
Max. operating pressure on wet side	600								kPa
Total water content of recovery exchangers	1.8		2.6			8.6			l

Specifications of the unit

Recovered heating capacity	43	47	50	58	65	71	80	88	kW
Recovered water flow rate	2.05	2.25	2.39	2.77	3.11	3.39	3.82	4.20	l/s
Recovered water pressure drop	21	25	27	29	36	42	5	6	kPa

The data refer to: Water temperature: evaporator inlet :12°C - evaporator outlet: 7°C, Outdoor air temperature 35°C.
The data refer to: Water temperature: recovery inlet :40°C - recovery outlet: 45°C.

TECH. SPEC. & STD PERF. - SPECIAL VERSIONS - IR UNITS FOR COOLING ONLY

Partial Recovery Version (VP)

Recovery heat exchanger specifications

Model	150	165	180	205	230	260	285	315	MU
Type of recovery exchanger	BRAZE WELDED STAINLESS STEEL PLATES								/
Quantity	1								N°
Max. operating pressure on wet side	1000								kPa
Total water content of recovery exchangers	11.6			14,7			17.9		l

Specifications of the unit

Recovered heating capacity	105	123	123	142	158	173	216	216	kW
Recovery water flow rate	5.02	5.88	5.88	6.78	7.55	8.27	10.3	10.3	l/s
Recovery water pressure drop	32	43	43	31	38	45	53	53	kPa

The data refer to: Water temperature: evaporator inlet :12°C - evaporator outlet: 7°C,
The data refer to: Water temperature: recovery inlet :40°C - recovery outlet: 45°C.

Total Recovery version (VR)

Recovery heat exchanger specifications

Model	150	165	180	205	230	260	285	315	MU
Type of recovery exchanger	BRAZE WELDED STAINLESS STEEL PLATES								/
Quantity	2								N°
Max. operating pressure on wet side	1000								kPa
Total water content of recovery exchangers	20.2			29,4			35.7		l

Specifications of the unit

Recovered heating capacity	209	228	246	284	315	346	390	431	kW
Recovered water flow rate	9.99	10.9	11.8	13.6	15.1	16.5	18.6	20.6	l/s
Recovered water pressure drop	32	37	43	31	38	45	43	43	kPa

The data refer to: Water temperature: evaporator inlet :12°C - evaporator outlet: 7°C, Outdoor air temperature 35°C.
The data refer to: Water temperature: recovery inlet :40°C - recovery outlet: 45°C.

Brine Version (VI)

Correction factors to apply to the basic version data

Brine percentage	10%				20%				30%				40%			
	7°C	4°C	-2 °C	-6 °C	7°C	4°C	-2 °C	-6 °C	7°C	4°C	-2 °C	-6 °C	7°C	4°C	-2 °C	-6 °C
Produced water temperature	7°C	4°C	-2 °C	-6 °C	7°C	4°C	-2 °C	-6 °C	7°C	4°C	-2 °C	-6 °C	7°C	4°C	-2 °C	-6 °C
Cooling capacity c.f.	0.99	0.90	0.69	/	0.98	0.90	0.68	0.56	0.97	0.89	0.68	0.56	0.95	0.87	0.66	0.54
Power input c.f.	1.00	0.95	0.86	/	0.99	0.94	0.85	0.79	0.99	0.94	0.85	0.79	0.98	0.93	0.84	0.78
Water flow rate c.f.	1.04	0.93	0.73	/	1.08	0.95	0.75	0.62	1.12	0.98	0.78	0.65	1.16	1.02	0.81	0.67
Water pressure drop c.f.	1.08	0.88	0.61	/	1.16	0.89	0.74	0.49	1.25	0.97	0.81	0.53	1.35	1.05	0.88	0.58

A calculation example showing how the table is used is given below.

Consider unit **IR 180.4** in the Basic Version with:

- Cooling capacity of the Basic Version unit (VB): $P_{f_{VB}} = 177 \text{ kW}$
- Power input of Compressors in Basic Version unit (VB): $Pass_{CP,VB} = 64 \text{ kW}$
- Water Flow Rate of Basic Version unit (VB): $Q_{VB} = 8.46 \text{ l/s}$
- Water Pressure Drop of Basic Version unit (VB): $\Delta p_{VB} = 40 \text{ kPa}$
- with 30% brine and -2°C temperature of the water produced

The corresponding values for the Brine Version are:

- Cooling capacity $P_{f_{VI}} = P_{f_{VB}} \times (0.68) = 120 \text{ kW}$
- Compressor power input $Pass_{CP,VI} = Pass_{CP,VB} \times (0.85) = 54 \text{ kW}$
- Water flow rate $Q_{VI} = Q_{VB} \times (0.78) = 6.60 \text{ l/s}$
- Water pressure drop $\Delta p_{VI} = \Delta p_{VB} \times (0.81) = 32 \text{ kPa}$

Noise levels of Special Versions

Refer to the indications in the Technical Bulletin of the Basic Version of the IR units (Basic version and Silenced version) for the noise levels.

TECH. SPEC. & STD PERF. - SPECIAL VERSIONS - IR UNITS FOR COOLING ONLY

Standard Version Performances of Version with Desuperheater (VD)

The table below lists the Recovered Heating Capacity values for each unit and for different outdoor air and recovered water temperatures.

MODEL	TWR	OUTDOOR AIR TEMPERATURE (°C D.B.)				
		25	30	35	40	45
		kW _t = RECOVERED HEATING CAPACITY [KW]				
150	40	37.4	46.3	52.0	57.9	63.5
	45	29.6	38.6	43.0	50.9	56.3
	50	21.8	31.0	36.6	43.9	49.1
	55	16.1	24.8	31.1	37.8	42.9
	60	11.9	19.9	26.4	32.6	37.4
	65	8.77	15.9	22.4	28.1	32.6
	70	6.47	12.8	19.1	24.3	28.5
165	40	40.8	50.6	56.9	63.2	69.4
	45	32.4	42.2	47.0	55.6	61.6
	50	23.9	33.8	40.0	47.9	53.7
	55	17.6	27.1	34.0	41.3	46.8
	60	13.0	21.7	28.9	35.7	40.9
	65	9.58	17.4	24.5	30.7	35.6
	70	7.07	13.9	20.9	26.5	31.1
180	40	43.4	53.9	60.5	67.3	73.9
	45	34.4	44.9	50.0	59.1	65.5
	50	25.4	36.0	42.5	51.0	57.1
	55	18.7	28.84	36.1	44.0	49.8
	60	13.8	23.1	30.7	37.9	43.5
	65	10.2	18.5	26.1	32.7	37.9
	70	7.52	14.8	22.2	28.2	33.1
205	40	50.4	62.5	70.2	78.0	85.7
	45	39.9	52.1	58.0	68.6	76.0
	50	29.5	41.8	49.3	59.2	66.3
	55	21.7	33.5	41.9	51.0	57.8
	60	16.0	26.8	35.6	44.0	50.4
	65	11.8	21.5	30.3	37.9	44.0
	70	8.73	17.2	25.7	32.7	38.4
230	40	56.5	70.0	78.7	87.5	96.0
	45	44.7	58.4	65.0	76.9	85.1
	50	33.0	46.8	55.3	66.3	74.3
	55	24.4	37.5	47.0	57.2	64.8
	60	18.0	30.0	39.9	49.3	56.5
	65	13.3	24.1	33.9	42.5	49.3
	70	9.78	19.3	28.8	36.7	43.0
260	40	61.7	76.5	85.9	95.5	105
	45	48.9	63.8	71.0	84.0	93.0
	50	36.1	51.1	60.4	72.4	81.1
	55	26.6	41.0	51.3	62.5	70.8
	60	19.6	32.8	43.6	53.9	61.7
	65	14.5	26.3	37.1	46.4	53.9
	70	10.7	21.1	31.5	40.0	47.0
285	40	69.5	86.2	96.8	108	118
	45	55.1	71.9	80.0	94.6	105
	50	40.6	57.6	68.0	81.6	91.4
	55	30.0	46.1	57.8	70.4	79.7
	60	22.1	37.0	49.1	60.7	69.6
	65	16.3	29.6	41.8	52.3	60.7
	70	12.0	23.7	35.5	45.1	52.9
315	40	76.5	94.8	106	118	130
	45	60.6	79.1	88.0	104	115
	50	44.7	63.4	74.8	89.8	101
	55	33.0	50.8	63.6	77.4	87.7
	60	24.3	40.7	54.0	66.7	76.5
	65	17.9	32.6	45.9	57.6	66.7
	70	13.2	26.1	39.0	49.6	58.2

TWR: Recovered Water temperature (°C)

TECH. SPEC. & STD PERF. - SPECIAL VERSIONS - IR UNITS FOR COOLING ONLY

Standard Performances of Partial Recovery Version (VP)

The table below lists the Recovered Heating Capacity values for each unit and for different produced cold water and recovered water temperatures, when the unit is operating in the Recovery mode.

MODEL	TWE	RECOVERED WATER TEMPERATURE (°C D.B.)			
		35	40	45	50
		kW _t = RECOVERED HEATING CAPACITY [KW]			
150	5	104	101	100	97
	6	107	104	102	99
	7	109	107	105	102
	8	112	110	107	104
	9	115	112	110	107
	10	119	116	113	110
165	5	121	119	118	115
	6	125	123	120	117
	7	128	126	123	120
	8	132	129	126	123
	9	135	132	130	126
	10	139	136	133	130
180	5	121	119	118	115
	6	125	123	120	117
	7	128	126	123	120
	8	132	129	126	123
	9	135	132	130	126
	10	139	136	133	130
205	5	139	137	136	133
	6	143	141	139	134
	7	147	145	142	137
	8	151	148	146	141
	9	155	152	150	145
	10	159	156	154	151
230	5	155	152	151	148
	6	159	157	155	149
	7	164	161	158	153
	8	168	165	162	157
	9	172	169	167	161
	10	177	173	171	168
260	5	168	165	164	162
	6	173	170	169	163
	7	178	175	173	167
	8	182	179	177	171
	9	187	184	181	176
	10	192	188	185	182
285	5	211	207	206	202
	6	217	213	211	204
	7	223	220	216	209
	8	229	225	222	215
	9	234	230	227	220
	10	240	235	232	228
315	5	211	207	206	202
	6	217	213	211	204
	7	223	220	216	209
	8	229	225	222	215
	9	234	230	227	220
	10	240	235	232	228

TWE: Temperature of Water at Evaporator outlet (°C)

TECH. SPEC. & STD PERF. - SPECIAL VERSIONS - IR UNITS FOR COOLING ONLY

Standard Performances of Total Recovery version (VR)

The table below lists the Recovered Heating Capacity values for each unit and for different produced cold water and recovered water temperatures, when the unit is operating in the Recovery mode.

MODEL	TWE	RECOVERED WATER TEMPERATURE (°C D.B.)			
		35	40	45	50
		kW _t = RECOVERED HEATING CAPACITY [KW]			
150	5	207	203	199	194
	6	213	209	204	199
	7	218	214	209	204
	8	224	219	214	208
	9	230	225	220	213
	10	237	231	226	220
165	5	225	221	217	212
	6	232	227	222	216
	7	237	233	228	222
	8	244	239	233	227
	9	251	245	240	232
	10	258	251	246	240
180	5	243	238	235	230
	6	250	245	241	234
	7	257	252	246	239
	8	263	258	253	245
	9	271	265	260	251
	10	278	272	266	260
205	5	278	273	271	266
	6	287	281	278	268
	7	295	289	284	275
	8	303	297	292	282
	9	311	304	299	289
	10	319	312	307	301
230	5	308	302	300	295
	6	317	311	307	297
	7	325	320	315	304
	8	334	328	323	312
	9	343	336	331	320
	10	351	344	339	333
260	5	337	331	329	323
	6	346	341	337	325
	7	356	351	346	334
	8	365	359	354	343
	9	374	367	362	351
	10	383	376	371	364
285	5	381	374	371	365
	6	391	385	381	367
	7	402	396	390	377
	8	412	405	400	387
	9	423	415	409	396
	10	433	424	419	411
315	5	420	413	410	403
	6	432	425	420	406
	7	443	437	431	416
	8	455	448	441	427
	9	467	458	452	438
	10	478	468	462	454

TWE: Temperature of Water at Evaporator outlet (°C)

TECH. SPEC. & STD PERF. - SPECIAL VERSIONS - IP HEAT PUMP UNITS

General technical specifications

The following data refer to IP units using R407C refrigerant

Model	150	165	180	205	230	260	285	315	MU
Shipping volume of unit	17.6								m ³

Compressor specifications

Type	SCROLL								/
Quantity	4								N°

Exchanger data

Type	WITH PLATES								/
Quantity	1								N°
Water capacity	11.4	13.3	14.3	23.9	27.5	30.2	32.9	37.4	l

Water tank specifications (1)

Water capacity	700								l
----------------	-----	--	--	--	--	--	--	--	---

(1): The water storage tank is an accessory that must be requested when the unit is ordered.

Specifications of coils with extended surfaces

Type	COPPER PIPES NOTCHED ALUMINIUM FINNS								/	
Quantity	4								N°	
Total area	11.6								m ²	
N° Fans diameter 800 mm	4		4	6*	4	6*	6	6	6	N°

(*): Fans installed in Silenced Version only.

Basic version

Technical specifications of Basic Version AB-7M5

Model	150	165	180	205	230	260	285	315	UM	
Net cooling capacity ⁽²⁾	136	150	164	192	214	237	273	299	kW	
Net heating capacity ⁽³⁾	165	181	197	230	257	284	317	350	kW	
Net total power input	In cooling mode ⁽²⁾	60.4	66.5	72.7	82.3	93.5	103	116	127	kW
	In heating mode ⁽³⁾	62.8	67.5	72.4	81.9	89.9	102	112	124	kW
Gross cooling capacity ^{(2)(E)}	-	-	165	193	215	238	275	301	kW	
Gross heating capacity ^{(3)(E)}	-	-	195	228	255	282	314	347	kW	
Gross total power input ^(E)	In cooling mode ⁽²⁾	-	-	71.7	81.1	92.3	102	114	124	kW
	In heating mode ⁽³⁾	-	-	70.9	80.0	87.9	99.7	109	120	kW

Technical specifications of Silenced Version AS-7M5

Net cooling capacity ⁽²⁾	132	146	160	186	208	230	270	296	kW	
Net heating capacity ⁽³⁾	160	175	192	222	250	276	318	350	kW	
Net total power input	In cooling mode ⁽²⁾	62.4	67.5	72.7	82.9	93.7	102	113	122	kW
	In heating mode ⁽³⁾	58.6	63.1	69.0	78.3	87.7	96	107	118	kW
Gross cooling capacity ^{(2)(E)}	-	-	161	187	209	231	272	298	kW	
Gross heating capacity ^{(3)(E)}	-	-	191	220	248	274	315	347	kW	
Gross total power input ^(E)	In cooling mode ⁽²⁾	-	-	71.9	82.0	92.5	100	111	120	kW
	In heating mode ⁽³⁾	-	-	67.5	76.4	85.8	93.8	103	114	kW

(2): The data refer to: Water temperature: inlet: 12°C - outlet: 7°C.
Outdoor air temperature 35°C D.B.

(3): The data refer to: Water temperature: inlet: 40°C - outlet: 45°C.
Outdoor air temperature 7°C D.B., 6°C W.B.

(E): Data certificated by EUROVENT.

Version with Desuperheater (VD)

Recovery heat exchanger specifications

Model	150	165	180	205	230	260	285	315	MU
Type of recovery exchanger	BRAZE WELDED STAINLESS STEEL PLATES								/
Quantity	2								N°
Max. operating pressure on wet side	600								kPa
Total water content of recovery exchangers	1.8		2.6			8.6			l

Specifications of the unit

Recovered heating capacity	40.0	45	48	56	63	69	78	87	kW
Recovered water flow rate	1.91	2.15	2.29	2.68	3.01	3.30	3.73	4.16	l/s
Recovered water pressure drop	18	23	25	27	34	40	5	6	kPa

The data refer to: Water temperature: evaporator inlet: 12°C - evaporator outlet: 7°C, Outdoor air temperature 35°C.

The data refer to: Water temperature: recovery inlet: 40°C - recovery outlet: 45°C.



NOTE : THE HEATING CAPACITY RECOVERED BY THE DESUPERHEATER EXCLUSIVELY REFERS TO UNITS OPERATING IN THE COOLING MODE.

Noise levels of Special Versions

Refer to the indications in the Technical Bulletin of the Basic Version of the IP units (Basic version and Silenced version) for the noise levels.

TECH. SPEC. & STD PERF. - SPECIAL VERSIONS - IP HEAT PUMP UNITS

Standard Version Performances of Version with Desuperheater (VD)

The table below lists the Recovered Heating Capacity values for each unit and for different outdoor air and recovered water temperatures.

MODEL	TWR	OUTDOOR AIR TEMPERATURE (°C D.B.)				
		25	30	35	40	45
		kW _t = RECOVERED HEATING CAPACITY [KW]				
150	40	34.8	43.1	48.4	53.8	59.1
	45	27.5	35.9	40.0	47.3	52.4
	50	20.3	28.8	34.0	40.8	45.7
	55	15.0	23.1	28.9	35.2	39.9
	60	11.1	18.5	24.6	30.3	34.8
	65	8.16	14.8	20.9	26.2	30.3
	70	6.02	11.9	17.7	22.6	26.5
165	40	39.1	48.5	54.5	60.6	66.5
	45	31.0	40.4	45.0	53.2	58.9
	50	22.9	32.4	38.3	45.9	51.4
	55	16.9	26.0	32.5	39.6	44.9
	60	12.4	20.8	27.6	34.1	39.1
	65	9.18	16.7	23.5	29.4	34.1
	70	6.77	13.3	20.0	25.4	29.8
180	40	41.7	51.7	58.1	64.6	70.9
	45	33.0	43.1	48.0	56.8	62.9
	50	24.4	34.6	40.8	49.0	54.8
	55	18.0	27.7	34.7	42.2	47.8
	60	13.3	22.2	29.5	36.4	41.7
	65	9.79	17.8	25.1	31.4	36.4
	70	7.22	14.2	21.3	27.1	31.8
205	40	48.7	60.3	67.8	75.4	82.7
	45	38.5	50.3	56.0	66.2	73.3
	50	28.4	40.3	47.6	57.1	64.0
	55	21.0	32.3	40.5	49.3	55.8
	60	15.5	25.9	34.4	42.5	48.7
	65	11.4	20.7	29.2	36.6	42.5
	70	8.42	16.6	24.8	31.6	37.1
230	40	54.7	67.9	76.2	84.8	93.1
	45	43.4	56.6	63.0	74.5	82.5
	50	32.0	45.4	53.6	64.3	72.0
	55	23.6	36.3	45.5	55.4	62.8
	60	17.4	29.1	38.7	47.8	54.8
	65	12.8	23.3	32.9	41.2	47.8
	70	9.48	18.7	28.0	35.5	41.7
260	40	59.9	74.3	83.5	92.8	102
	45	47.5	62.0	69.0	81.6	90.4
	50	35.0	49.7	58.7	70.4	78.8
	55	25.9	39.8	49.9	60.7	68.8
	60	19.1	31.9	42.4	52.3	60.0
	65	14.1	25.5	36.0	45.1	52.3
	70	10.4	20.5	30.6	38.9	45.7
285	40	67.8	84.0	94.4	105	115
	45	53.7	70.1	78.0	92.3	102
	50	39.6	56.2	66.3	79.6	89.1
	55	29.2	45.0	56.4	68.6	77.7
	60	21.6	36.0	47.9	59.2	67.8
	65	15.9	28.9	40.7	51.0	59.2
	70	11.7	23.1	34.6	44.0	51.6
315	40	75.6	93.7	105	117	128
	45	59.9	78.2	87.0	103	114
	50	44.2	62.6	74.0	88.7	99.4
	55	32.6	50.2	62.9	76.5	86.7
	60	24.0	40.2	53.4	66.0	75.6
	65	17.7	32.2	45.4	56.9	66.0
	70	13.1	25.8	38.6	49.1	57.6

TWR: Recovered Water temperature (°C)

OPERATING RANGE

Operating limits

The table below lists the operating ranges within which correct operation of the units is guaranteed, depending on the Version and Operating Mode available for each type of unit (Cooling Mode only IR or Heat Pump IP). Remember that in Heat Pump units, heat recovery only takes place during operation in the cooling mode.

Operating range for IR Units that operate in the Cooling mode only

Unit type Cooling mode only	Version	Operating mode		
		COOL	HEAT	RECOVERY
IR	Basic (VB)	See Basic Version Bulletin	/	/
	with Desuperheater (VD)	As Basic version	/	Recovery water temp. from 40 to 70°C (Refer to Desuperheater Standard Performances table)
	Partial Recovery Version (VP)	As Basic version	/	See Graph below
	Total Recovery (VR)	As Basic version	/	See Graph below

Operating range of IP Heat Pump units

Unit type Heat Pump	Version	Operating mode		
		COOL	HEAT	RECOVERY
IP	Basic (VB)	See Basic Version Bulletin	See Basic Version Bulletin	/
	with Desuperheater (VD)	As Basic version	/	Recovery water temp. from 40 to 70°C (Refer to Desuperheater Standard Performances table)

Total Recovery (VR) and Partial Recovery (VP) versions of unit

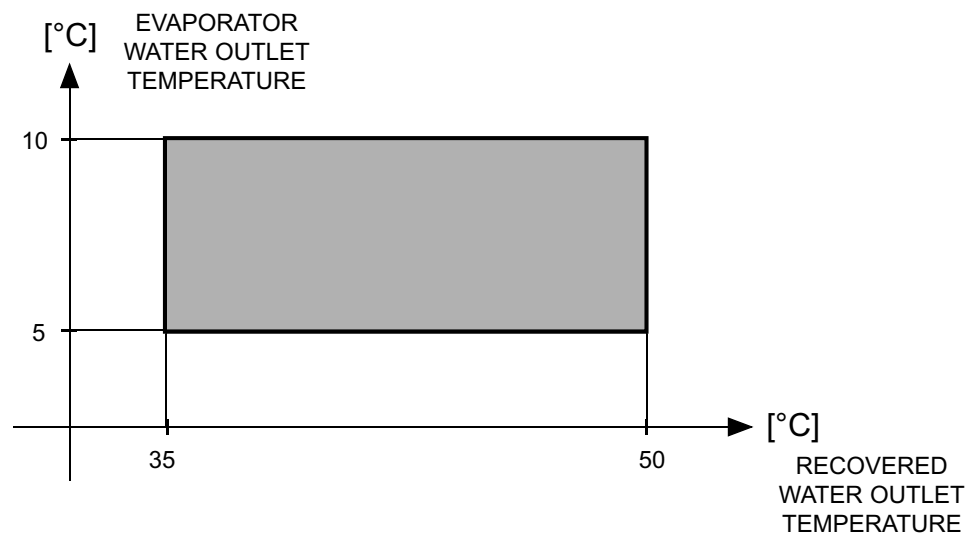

HOW TO SELECT THE UNIT

Foreword

To select the Special Version (VD, VP or VR) correctly and achieve the specific performances required, proceed in two phases and first select the unit that satisfies the conditions of the Basic project. After having identified the Basic unit model, proceed by identifying the Special Version (VD, VP or VR) most able to suit the Recovery conditions required.

To select the Basic Version of the unit (VB), refer to the Technical Commercial Bulletins of the Basic Version with the Standard Performance tables (in the cooling and/or heating modes) of the type of unit in question (IR Cooling mode only or IP Heat pump). These tables give the Cooling Capacity supplied in the cooling mode and the Heating Capacity provided in the heating mode (for IP units only) for each unit and for the different temperature values of the outdoor air and water leaving the unit, along with the power input values of the compressors of the individual units in standard conditions (remember that the data may be interpolated but not extrapolated).

Special Versions

This bulletin contains information about the Special Versions alone (VD, VP or VR). In particular:

- 1) The "Standard Performances of the Version with Desuperheater" section gives the Recovered Heating Capacity values for each unit and for various temperature values of the outdoor air and recovered water, this for both types of unit (Cooling mode only IR or Heat pump IP).
- 2) The "Standard Performances of the Total recovery Version" section (version only available for units IR that operate in the cooling mode only) gives the Recovered Heating Capacity values values when the unit operates in the Recovery mode for each unit and for various temperature values of the cold water produced air and recovered water.
- 3) The "Standard Performances of the Partial Recovery Version" section (version only available for units IR that operate in the cooling mode only) gives the Recovered Heating Capacity values values when the unit operates in the Recovery mode for each unit and for various temperature values of the cold water produced air and recovered water.
- 4) Remember that the Cooling Capacity and Heating Capacity values provided by the units in the Standard operating mode are given in the Standard Performances tables of the Technical Bulletins of the respective Basic Versions and refer to 5°C of Δt of the water between the evaporator's inlet and outlet.
- 5) Also remember that the values in the Standard Performances tables of the Technical Bulletins of the Basic Versions refer to units installed in places at zero meters above sea level ($P_b = 1013$ mbar) and are based on an exchanger fouling factor on the wet side equal to $0.44 \cdot 10^{-4} \text{ m}^2 \text{ }^\circ\text{C} / \text{W}$.
- 6) When selecting the unit in relation to the standard conditions of the project alone and before going into detail and selecting the Special Version, refer to the selection procedure in the Technical Bulletins of the Basic Version and then apply the same corrective factors to the efficiency ratings listed in the Technical Bulletins of the Basic Versions. Use efficiency correction value F_{cD} for the thermal gradient if there are different values in the case of operation in the cooling mode. Corrective factor F_{cD} is not considered in the heating mode as its influence is negligible.

Example N°1 - Selection of Special version of IR unit - Cooling Mode only

Basic Project Conditions

The unit must be able to supply a 203 kW cooling capacity in the following conditions:

- Outdoor air temperature = 32°C
- Temperature of the cold water outlet by the machine = 7°C
- Water inlet/outlet temperature gradient $\Delta t = 6^\circ\text{C}$

Also consider:

- a $0.88 \cdot 10^{-4} \text{ m}^2 \text{ }^\circ\text{C} / \text{W}$ evaporator fouling factor
- unit installed in a place at 600 meters above sea level.

Conditions in the Recovery Circuit

Case 1) The unit must be able to supply a 32 kW Heating Capacity in the following conditions:

- Outdoor air temperature = 32°C (as Basic Project condition)
- Produced water temperature = 55°C with $\Delta t = 5^\circ\text{C}$
- A $0.88 \cdot 10^{-4} \text{ m}^2 \text{ }^\circ\text{C} / \text{W}$ evaporator fouling factor
- Unit installed in a place at 600 meters above sea level.

Case 2)

The unit must be able to supply a 135 kW Heating Capacity in the following conditions:

- Outdoor air temperature = 32°C (as Basic Project condition)
- Produced water temperature = 45°C with $\Delta t = 7^\circ\text{C}$
- Temperature of the cold water outlet by the machine = 7°C
- A $0.88 \cdot 10^{-4} \text{ m}^2 \text{ }^\circ\text{C} / \text{W}$ evaporator fouling factor

HOW TO SELECT THE UNIT

Case 3)

The unit must be able to supply a 260 kW Heating Capacity in the following conditions:

- Outdoor air temperature = 32°C (as Basic Project condition)
- Produced water temperature = 50°C with $\Delta t = 7^\circ\text{C}$
- Temperature of the cold water outlet by the machine = 7°C
- A $0.44 \times 10^{-4} \text{m}^2\text{C/W}$ fouling factor

Solution:

In view of the operating specifications required, a basic version of the unit can be chosen as there are no particular limitations concerning acoustic emission.

Beginning with the Basic Project conditions and with reference to the Technical Bulletin of the Basic Version of the IR unit that operates in the Cooling Mode only, proceed by selecting model **RLA IR 205.4 VB AB 7M5** which, with a 32°C air temperature and water outlet by the machine at 7°C, supplies a 211 kW cooling capacity (value obtained by interpolation) and an acoustic pressure level of 76 dB(A) at a distance of one meter.

The effective cooling capacity provided by the machine in the real conditions of use will be:

$$P_f = P_{fs} \times F_{cH} \times F_{cP}$$

Where:

P_f = refrigerating capacity provided in the real operating conditions (kW)

P_{fs} = refrigerating capacity provided in standard conditions (kW)

FCD = correction factor for the temperature gradient

FCH = correction factor for the height above sea level

FCP = correction factor for the fouling factor

Using the available data and with the aid of the corrective factor tables in the Technical Bulletin of the Basic Version, determine factor FCD=1.012, FCH=0.98, FCP=0.98 and then calculate the cooling capacity supplied in the real operating conditions, i.e.:

$$P_f = (211) (1.012) (0.98) (0.98) = 205 \text{ kW}$$

With the given conditions of use, the initially selected model **RLA IR 205.4 VB AB 7M5** is therefore able to supply a cooling capacity of 205 kW, which satisfies the conditions of the basic project as to required Cooling efficiency.

Proceed as explained in the Technical Bulletin of the Basic Version of the IR unit that operates in the Cooling Mode only to obtain other information about how the unit should function during normal operation in the cooling only mode, such as the Water flow rate, the Pressure drops and the Working Head.

Once having identified the size of the unit (**IR 205.4 — AB7M5**) that satisfies the Basic Project conditions, proceed by identifying the Special Version most able to meet the Recovery Heating Capacity requirements.

Remember that the following Special Versions are available for the IR Cooling Mode only units:

-Version with Desuperheater. Produces cold water as in the basic version plus hot water at a temperature of 40 to 70°C at the same time, with heat recovery that ranges from 15 to 20% of the heating capacity that would otherwise be dispersed in the air.

-Version with Total Recovery. Produces cold water as in the basic version plus hot water at a temperature of 35 to 50°C at the same time, with total recovery of the heating capacity that would otherwise be dispersed in the air.

-Version with Partial Recovery. Produces cold water as in the basic version plus hot water at a temperature of 35 to 50°C at the same time, with total recovery of the heating capacity that would otherwise be dispersed in the air, but only from one single cooling circuit instead of both.

Case 1)

Beginning with the previously described Conditions in the Recovery Circuit, the Special Version with Desuperheater (VD) can be selected as it supplies a 36.9 kW Heating Capacity (value obtained by interpolation) at the required 32°C outdoor air temperature and 55°C recovered water conditions.

The effective recovered heating capacity the unit is able to supply in the real conditions of use will be:

$$P_t = P_{tr} \times F_{cH} \times F_{cP}$$

Where:

P_t = recovered heating capacity supplied in the real operating conditions (kW)

P_{tr} = recovered heating capacity supplied in standard conditions (kW)

F_{CH} = correction factor for the height above sea level

F_{CP} = correction factor for the fouling factor

Using the available data and with the aid of the corrective factor tables in the Technical Bulletin of the Basic Version, determine factor F_{CH}=0.98, F_{CP}=0.98, and then calculate the heating capacity recovered in the real operating conditions, i.e.:

$$P_t = (36.9) (0.98) (0.98) = 35.4 \text{ kW}$$

The initially selected Version with Desuperheater, **IR 205.4 VD AB7M5** supplies 35.4 kW recovered heating capacity which satisfies the project conditions.

The flow rate of the water that passes through the recovery exchanger will be:

$$Q = P_t / (c \times \Delta t) = 35.4 / (4.186 \times 5) = 1.69 \text{ l/s}$$

HOW TO SELECT THE UNIT

A 11 kPa water pressure drop is given in the “Desuperheater water pressure drop” graph, on a level with the determined water flow rate of the selected model.

This value is acceptable since it is within the limit values given in “Limits to use”.

Case 2)

Beginning with the previously described Conditions in the Recovery Circuit, the Special Version with Partial Recovery (VP) can be selected as it supplies a 142 kW Heating Capacity at the required 32°C outdoor air temperature and 45°C recovered water conditions.

The effective recovered heating capacity the unit is able to supply in the real conditions of use will be:

$$P_t = P_{tr} \times F_{CH}$$

Where:

P_t = recovered heating capacity supplied in the real operating conditions (kW)

P_{tr} = recovered heating capacity supplied in standard conditions (kW)

F_{CH} = correction factor for the height above sea level

Using the available data and with the aid of the corrective factor tables in the Technical Bulletin of the Basic Version, determine $F_{CH}=0.98$ and then calculate the recovered heating capacity supplied in the real operating conditions, i.e.:

$$P_t = (142) (0.98) = 139 \text{ kW}$$

Remember that the correction factor for the thermal gradient is not considered as its influence is negligible.

The initially selected Version with Total Recovery **IR 205.4 VP AB7M5** supplies 139 kW recovered heating capacity which satisfies the project conditions.

The flow rate of the water that passes through the recovery exchanger will be:

$$Q = P_t / (c \times \Delta t) = 139 / (4.186 \times 7) = 4.47 \text{ l/s}$$

A 13 kPa water pressure drop is given in the “Total Recovery water pressure drop” graph, on a level with the determined water flow rate of the selected model.

This value is acceptable since it is within the limit values given in “Limits to use”.

Case 3)

Beginning with the previously described Conditions in the Recovery Circuit, the Special Version with Total Recovery (VR) can be selected as it supplies a 275 kW Heating Capacity at the required 32°C outdoor air temperature and 50°C recovered water conditions.

The effective recovered heating capacity the unit is able to supply in the real conditions of use will be:

$$P_t = P_{tr} \times F_{CH}$$

Where:

P_t = recovered heating capacity supplied in the real operating conditions (kW)

P_{tr} = recovered heating capacity supplied in standard conditions (kW)

F_{CH} = correction factor for the height above sea level

Using the available data and with the aid of the corrective factor tables in the Technical Bulletin of the Basic Version, determine $F_{CH}=0.98$ and then calculate the recovered heating capacity supplied in the real operating conditions, i.e.:

$$P_t = (275) (0.98) = 270 \text{ kW}$$

Remember that the correction factor for the thermal gradient is not considered as its influence is negligible.

The initially selected Version with Total Recovery **IR 205.4 VR AB7M5** supplies 270 kW recovered heating capacity which satisfies the project conditions.

The flow rate of the water that passes through the recovery exchanger will be:

$$Q = P_t / (c \times \Delta t) = 270 / (4.186 \times 7) = 9.21 \text{ l/s}$$

A 15 kPa water pressure drop is given in the “Total Recovery water pressure drop” graph, on a level with the determined water flow rate of the selected model.

This value is acceptable since it is within the limit values given in “Limits to use”.

HOW TO SELECT THE UNIT

Example N°2 - Selection of Special Version of the IP Heat Pump unit

Basic Project Conditions

The unit must be able to supply a 220 kW cooling capacity in the following conditions:

- Outdoor air temperature = 38°C
- Temperature of the cold water outlet by the machine = 9°C
- Water inlet/outlet temperature gradient $\Delta t = 5^\circ\text{C}$

The unit must also be able to provide a 260 kW heating capacity at the following conditions:

- Outdoor air temperature = 7°C
- Relative humidity of the outdoor air = 70%
- Temperature of the hot water outlet by the machine = 50 °C
- Water inlet/outlet temperature gradient $\Delta t = 5^\circ\text{C}$

Also consider:

- a $0.44 \times 10^{-4} \text{m}^2\text{C/W}$ evaporator fouling factor
- unit installed at sea level

The unit must also guarantee an acoustic pressure level of less than 70 dB(A) measured one meter away from the machine.

Conditions in the Recovery Circuit

Case 1) The unit must be able to supply a 70 kW Heating Capacity in the following conditions:

- Outdoor air temperature = 38°C (as Basic Project condition)
- Produced water temperature = 45°C with $\Delta t = 5^\circ\text{C}$
- A $0.88 \times 10^{-4} \text{m}^2\text{C/W}$ recovery exchanger fouling factor

Solution:

The reversible chiller must first be chosen by selecting the machine that satisfies the project conditions in the cooling mode and by then checking that the machine selected is able to provide the power required in the heating mode.

In view of the limitation imposed by the sound level, the choice will be directed towards soundproofed units of the Silenced type.

Selection for operation in the cooling mode:

Beginning with the Basic Project conditions during operation in the Cooling mode and with reference to the Technical Bulletin of the Basic Version of the IP Heat Pump unit, proceed by selecting model **IP 260 VB AS7M5** which, with a 38°C air temperature and water outlet by the machine at 9°C, supplies a 236 kW standard cooling capacity (value obtained by interpolation) and an acoustic pressure level of 67 dB(A) at a distance of one meter, which satisfies the initial project requirements.

The flow rate of the water that passes through the evaporator will be:

$$Q = P_t / (c \times \Delta t) = 236 / (4.186 \times 5) = 11.3 \text{ l/s}$$

A 33 kPa water pressure drop is given in the "Water pressure drop" graph, on a level with the determined water flow rate of the selected model.

This value is acceptable since it is within the limit values given in "Limits to use".

Verification for operation in the heating mode:

Beginning with the Basic Project conditions during operation in the heating mode and with reference to the Technical Bulletin of the Standard Version of the IP Heat Pump unit, the heating capacity of the previously selected **IP 260 VB AS7M5** unit with a 7°C air temperature and water outlet by the machine at 50°C, is $P_{rs} = 278 \text{ kW}$.

Using the available data and with the aid of the corrective factor tables in the Technical Bulletin of the Basic Version, determine factor $F_{cUr} = 0.959$ and then calculate the heating capacity supplied in the real operating conditions, i.e.:

$$P_f = (278) (0.959) = 267 \text{ kW}$$

The correction factor for the thermal gradient is not considered in the heating mode as its influence is negligible.

In the given conditions of use, the selected unit provides a 267 kW heating capacity, which is more or less in keeping with requirements and confirms that the selected model is valid.

Since the flow rate of the water circulating around the exchanger is the same as the value found for operation in the cooling mode, the real thermal gradient in the heating mode can now be calculated.

$$\Delta t = \frac{P_r}{C \times Q}$$

ΔT_r = Real thermal gradient

Q = Water flow rate (operation in the cooling mode)

$c = 4.186 \text{ kJ/kg } ^\circ\text{C}$ specific heat of the water.

which can be used to find:

$$\Delta t = 267 / (4.186 \times 11.3) = 5.6^\circ\text{C}$$

HOW TO SELECT THE UNIT

During operation in the heating mode, the unit will therefore function with a 5.6°C real thermal gradient, which corresponds to an inlet water temperature of:

$$\text{inlet water } T = \text{outlet water } T - \Delta T_r = 50 - 5.6 = 44.4 \text{ } ^\circ\text{C}.$$

Once having identified the size of the unit (**IP 260.4 — AS7M5**) that satisfies the Basic Project conditions in both the cooling and heating modes, proceed by identifying the Special Version most able to meet the Recovery Heating Capacity requirements.

Remember that the only Special Version available for the IP Heat Pump unit is:

-Version with Desuperheater. Produces, during operation in the Cooling mode, cold water as in the standard version plus hot water at a temperature of 40 to 70°C at the same time, with heat recovery that ranges from 15 to 20% of the heating capacity that would otherwise be dispersed in the air.

Case 1)

The Special Version with Desuperheater (VD) of the previously selected unit supplies a 75.6 kW heating capacity (value obtained by interpolation) with an outdoor air temperature of 38°C and water produced by the recovery function at 45°C.

The effective recovered heating capacity the unit is able to supply in the real conditions of use will be:

$$P_t = P_r \times F_{cp}$$

Where:

P_t = recovered heating capacity supplied in the real operating conditions (kW)

P_r = recovered heating capacity supplied in standard conditions (kW)

F_{cp} = correction factor for the fouling factor

Using the available data and with the aid of the corrective factor tables in the Technical Bulletin of the Basic Version, determine $F_{cp}=0.98$ and then calculate the recovered heating capacity supplied in the real operating conditions, i.e.:

$$P_t = (75.6) (0.98) = 74 \text{ kW}$$

Remember that the correction factor for the thermal gradient is not considered as its influence is negligible.

The initially selected Version with Desuperheater **IP 260.4 VD AS7M5** supplies 74 kW recovered heating capacity which satisfies the project conditions.

The flow rate of the water that passes through the recovery exchanger will be:

$$Q = P_t / (c_p \Delta t) = 74 / (4.186 \times 5) = 3.53 \text{ l/s}$$

A 47 kPa water pressure drop is given in the “Desuperheater water pressure drop” graph, on a level with the determined water flow rate of the selected model.

This value is acceptable since it is within the limit values given in “Limits to use”.

WATER PRESSURE DROP OF THE DESUPERHEATER

The graph below illustrates the water pressure drop values in **kPa** depending on the flow rate in **liters/second**, for the Special Versions with Desuperheater (VD) in both the units that operate in the Cooling mode only (IR) and in Heat Pump units (IP). The operating range is delimited by the minimum and maximum values given in the next table.

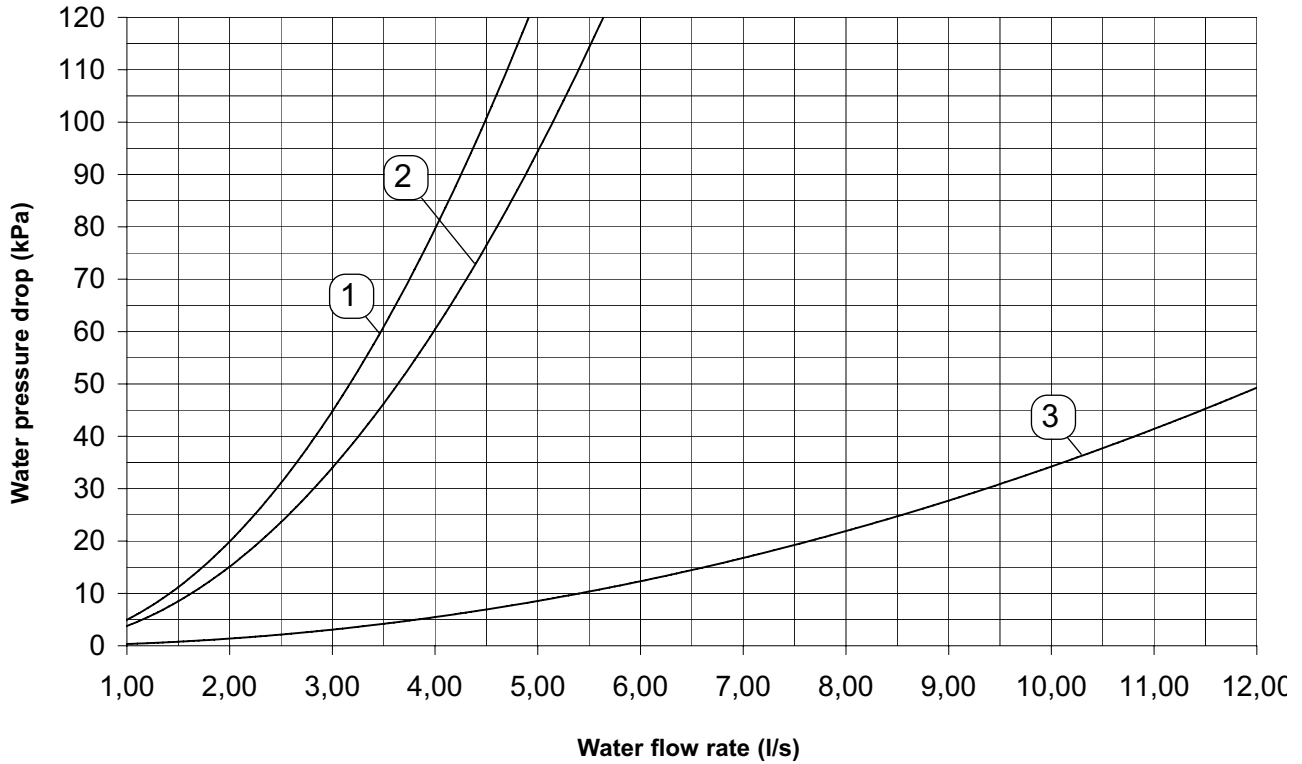

Limits to operation

Unit size		150	165	180	205	230	260	285	315	MU	
Graph reference		1			2			3			
Upper limit value	Water flow rate (Q)	1.00									l/s
	Water pressure drop (Δp)	5			4			1			kPa
Upper limit value	Water flow rate (Q)	4.9			5.6			12			l/s
	Water pressure drop (Δp)	120						50			kPa

WATER PRESSURE DROP WITH PARTIAL RECOVERY

The graph below illustrates the water pressure drop values in **kPa** depending on the flow rate in **liters/second**. The operating range is delimited by the minimum and maximum values given in the next table.

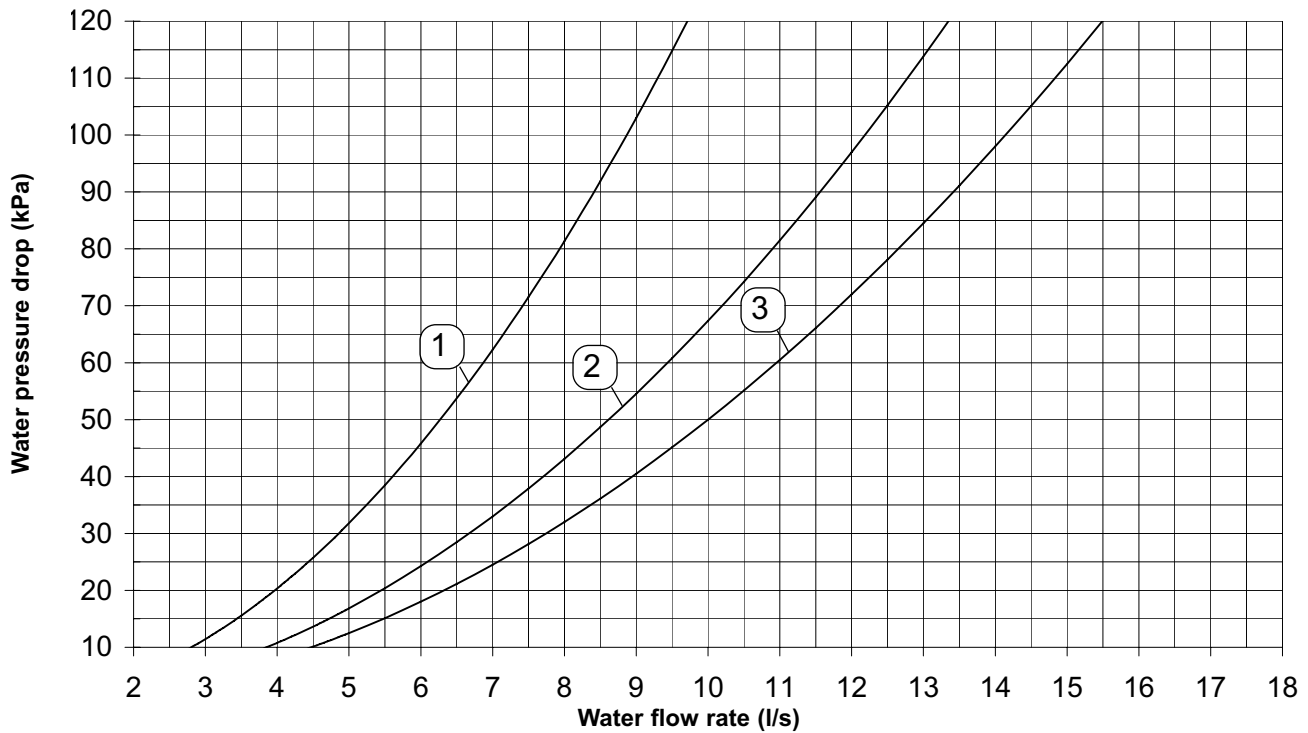

Limits to operation

Unit size		150	165	180	205	230	260	285	315	MU	NOTES
Graph reference		1			2			3			Q =Water flow rate Δp =Loss of pressure
Lower limit value	Q	2.7			3.8			4.5		l/s	
	Δp	10									
Upper limit value	Q	10.8			14.9			17.9		l/s	
	Δp	120									kPa

WATER PRESSURE DROP WITH TOTAL RECOVERY

The graph below illustrates the water pressure drop values in **kPa** depending on the flow rate in **liters/second**. The operating range is delimited by the minimum and maximum values given in the next table.

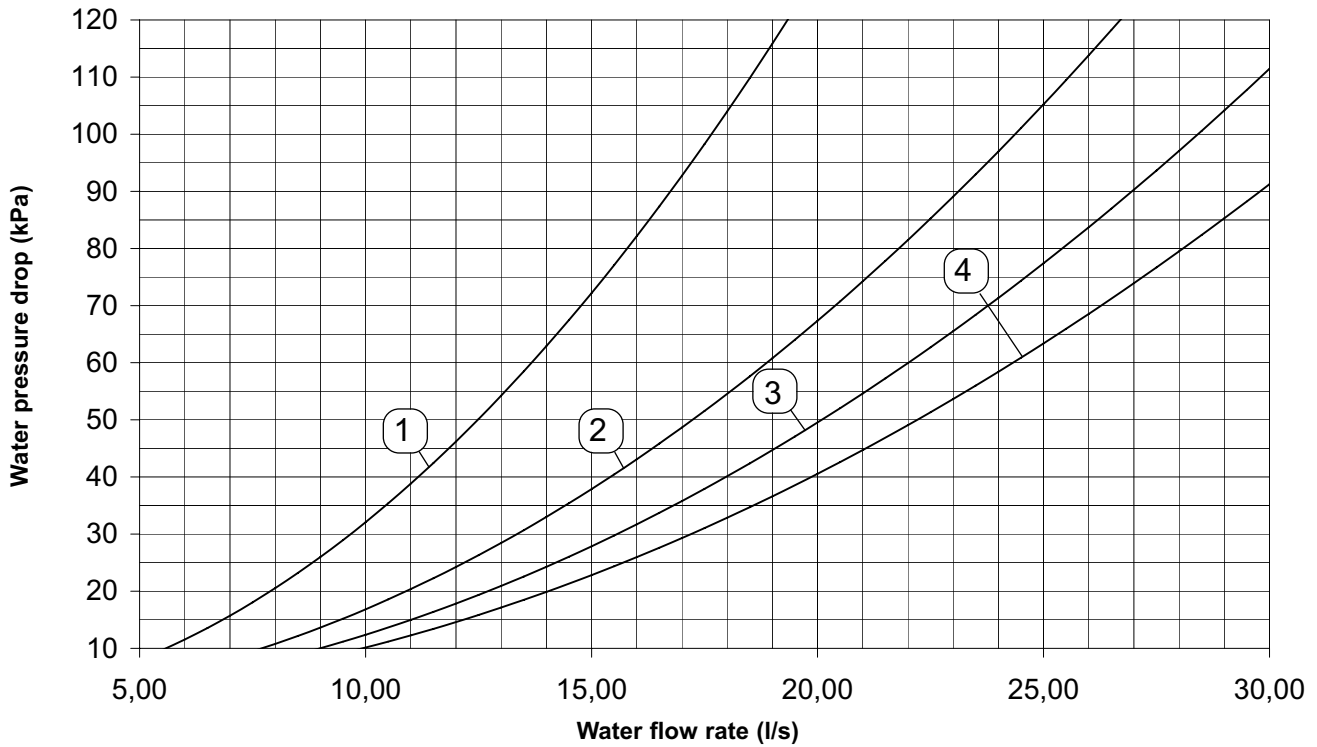

Limits to operation

Unit size		150	165	180	205	230	260	285	315	MU	NOTES
Graph reference		1			2			3	4		Q =Water flow rate Δp =Loss of pressure
Lower limit value	Q	5.7			7.8			9.0	10.0	l/s	
	Δp	10									
Upper limit value	Q	19.4			26.8			30		l/s	
	Δp	120						91	111	kPa	

OVERALL DIMENSIONS AND MINIMUM SPACE REQUIRED FOR OPERATION

Overall dimensions

Mod. 150.4 - 260.4

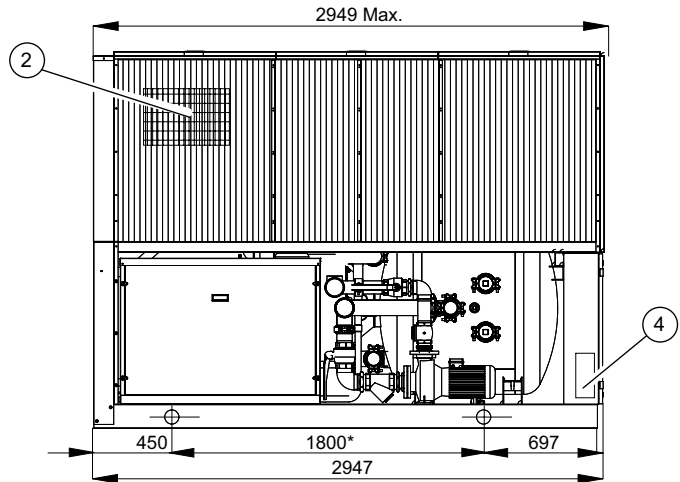
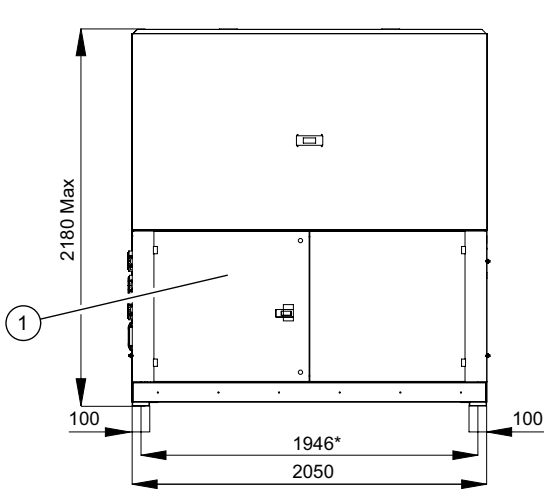

*Position of vibration damper holes = \varnothing 18mm

Mod. 285.4 - 315.4

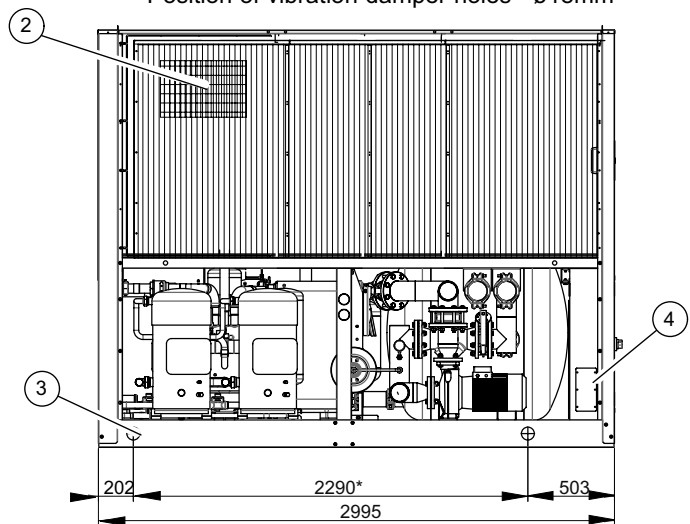
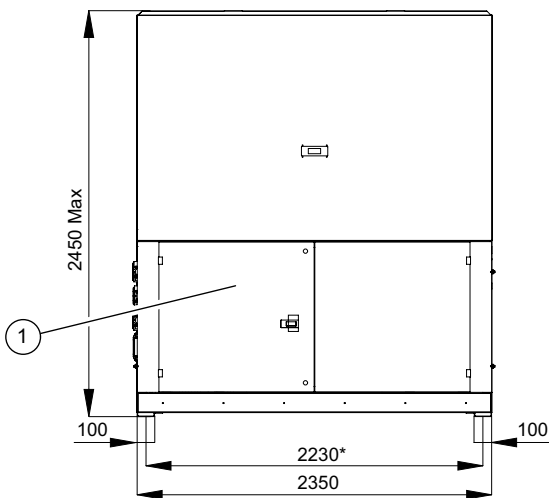

*Position of vibration damper holes = \varnothing 18mm

Description of the components

- 1 - Access panel to electric panel
- 2 - Coil protection grilles (accessory)
- 3 - \varnothing 82 mm lifting holes
- 4 - Input plate for power supply cables, unit and electrical accessories type (F) (120x250 mm - useful hole in cabinet 73x200)

Minimum space required for operation

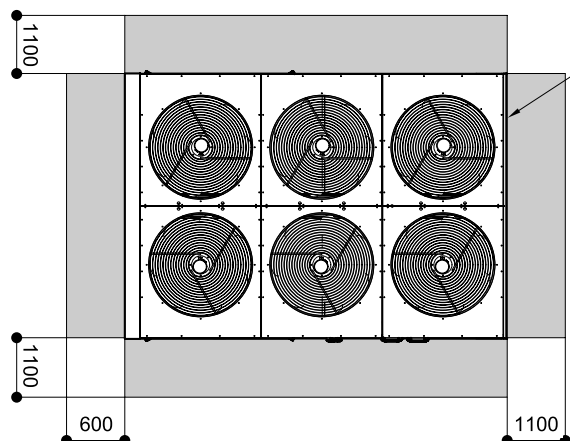

To correctly install the unit, comply with the measurements for the free area that must be left around the machine, as shown in the figure. This will ensure good air circulation, allow the unit to operate correctly and facilitate future maintenance work.

The distances must be doubled if the unit is to be installed in a pit.

NOTE: Allow for an uncluttered area of not less than 2.5 meters above the unit.

OVERALL DIMENSIONS AND MINIMUM SPACE REQUIRED FOR OPERATION

Position of wet connections

NOTE: Refer to the Installation Manual of the Basic Version of the units (VB) for the cold water connections.

IR UNIT FOR COOLING MODE ONLY

VD - Version with Desuperheater

Mod. 150-260

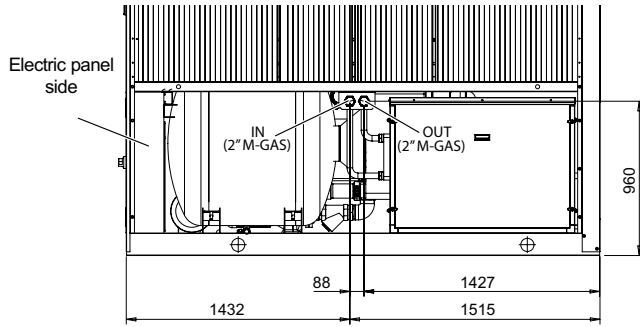

Mod. 285-315

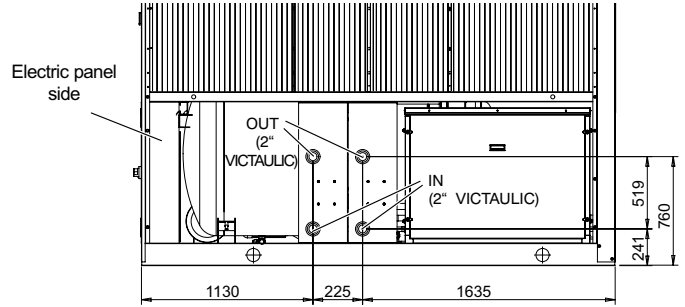

Weights in kg ⁽¹⁾

Model	150	165	180	205	230	260	285	315
Transport	2196	2311	2414	2710	2810	2823	3306	3479
Operation	2899	3107	3117	3414	3514	3527	4063	4241

(1) Operating weight relative to the unit of the heaviest series including the Water Storage Tank and Pumping Module.

VP - Version with Partial Recovery

Mod. 150-260

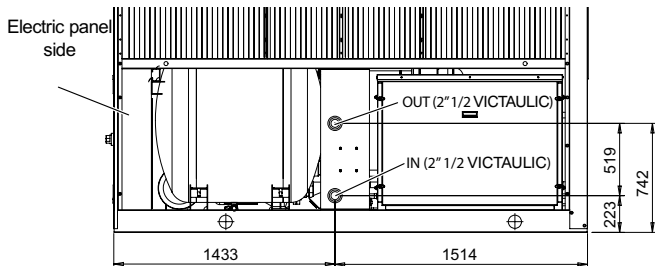

Mod. 285-315

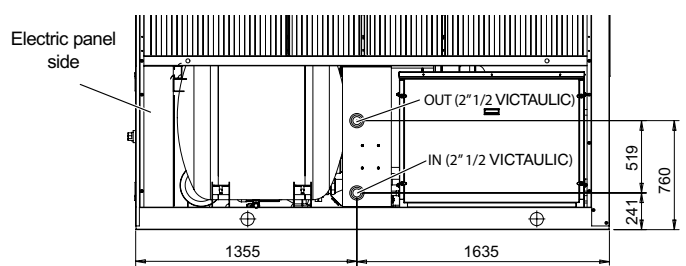

Weights in kg ⁽¹⁾

Model	150	165	180	205	230	260	285	315
Transport	2259	2374	2477	2804	2904	2917	3383	3556
Operation	2979	3187	3197	3534	3639	3657	4176	4354

(1) Operating weight relative to the unit of the heaviest series including the Water Storage Tank and Pumping Module.

OVERALL DIMENSIONS AND MINIMUM SPACE REQUIRED FOR OPERATION

VR - Total Recovery version

Mod. 150-260

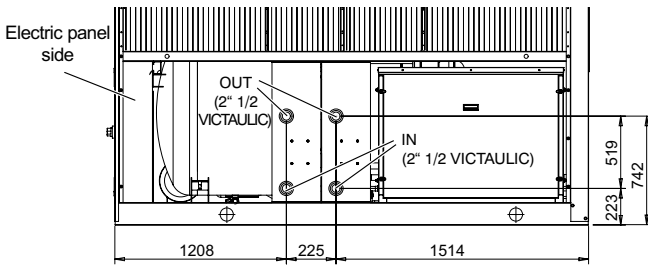

Mod. 285-315

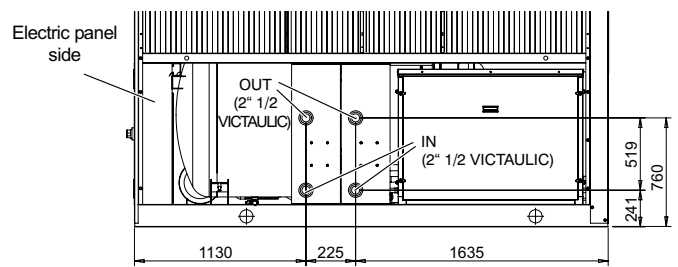

Weights in kg ⁽¹⁾								
Model	150	165	180	205	230	260	285	315
Transport	2359	2474	2577	2944	3044	3057	3536	3709
Operation	3099	3307	3317	3704	3814	3837	4369	4547

(1) Operating weight relative to the unit of the heaviest series including the Water Storage Tank and Pumping Module.

NOTE: The VICTAULIC connections are complete with grooved stub pipes pre-engineered for jointing the water pipes.

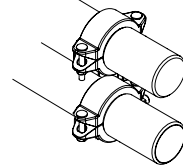

VI - Brine version

Refer to the Installation Manual of the Basic Version of the units (VB) for the positions of the wet connections.

IP HEAT PUMP UNIT

VD - Version with Desuperheater

Mod. 150÷260

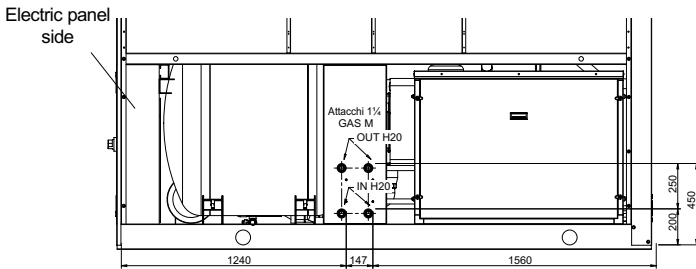

Mod. 285-315

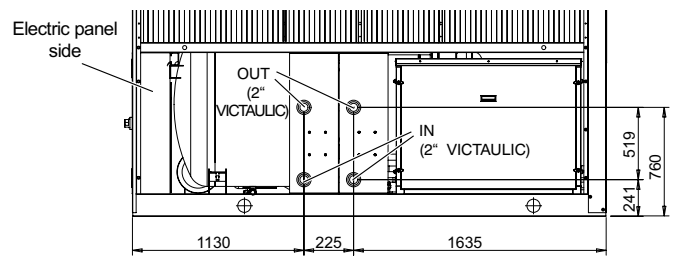

Weights in kg ⁽¹⁾								
Model	150	165	180	205	230	260	285	315
Transport	2380	2449	2559	2876	2977	2991	3500	3660
Operation	3083	3161	3262	3580	3681	3695	4257	4421

(1) Operating weight relative to the unit of the heaviest series including the Water Storage Tank and Pumping Module.

NOTE: The VICTAULIC connections are complete with grooved stub pipes pre-engineered for jointing the water pipes.

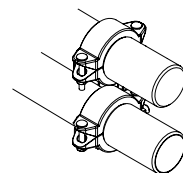

The manufacturer declines all responsibility for any inaccuracies in this manual due to printing or typing errors and reserves the right to modify the products contents in this catalogue without previous notice.



FERROLI S.p.A.

Via Ritonda, 78/a - 37047 San Bonifacio -
VERONA (Italy)

Tel.045/6139411 (r.a.)

Fax 045/6100233 - 6100933 - Tlx 480172